

MOBILE MIXER AMPLIFIER BROADCAST SYSTEM

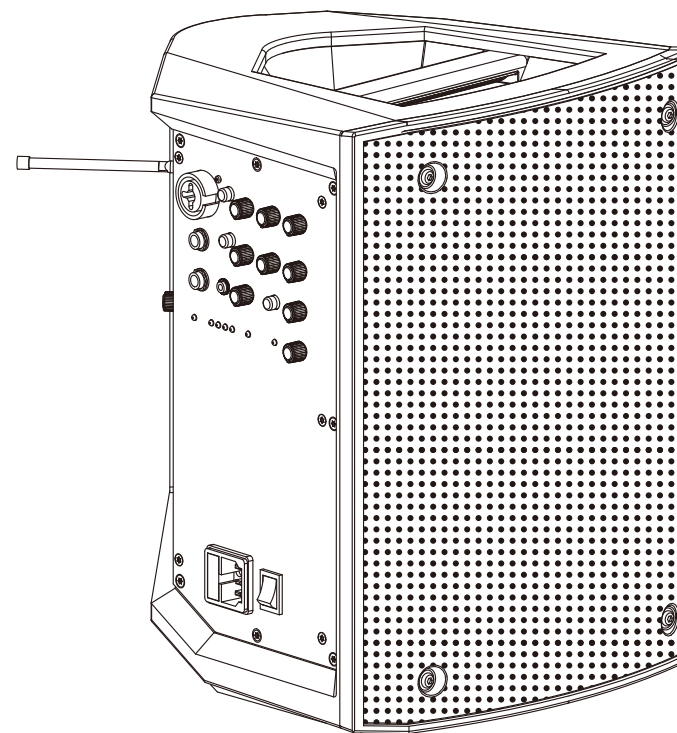

NF05628-1.2

FCC STATEMENT

1. This device complies with Part 15 of the FCC Rules. Operation is subject to the following two conditions:
 - (1) This device may not cause harmful interference, and
 - (2) This device must accept any interference received, including interference that may cause undesired operation.
2. Changes or modifications not expressly approved by the party responsible for compliance could void the user's authority to operate the equipment.

Radiation Exposure Statement

This equipment complies with FCC radiation exposure limits set forth for an uncontrolled environment. This equipment should be installed and operated with minimum distance 20cm between the radiator & your body.

NOTE: This equipment has been tested and found to comply with the limits for a Class B digital device, pursuant to Part 15 of the FCC Rules. These limits are designed to provide reasonable protection against harmful interference in a residential installation. This equipment generates, uses and can radiate radio frequency energy and, if not installed and used in accordance with the instructions, may cause harmful interference to radio communications. However, there is no guarantee that interference will not occur in a particular installation. If this equipment does cause harmful interference to radio or television reception, which can be determined by turning the equipment off and on, the user is encouraged to try to correct the interference by one or more of the following measures:

- Reorient or relocate the receiving antenna.
- Increase the separation between the equipment and receiver.
- Connect the equipment into an outlet on a circuit different from that to which the receiver is connected.
- Consult the dealer or an experienced radio/TV technician for help.

IMPORTANT!

**Please read this manual carefully before operating
this unit for the first time.**

11. ACCESSORIES

Power Cord	x 1
Wireless Microphone	x 1x 2
User Manual	x 1
Battery	x 1

12. CAUTION

1. Do not use any volatile solvents such as toluene, Alcohol or gasoline for safety, keep product clean and free from dust.
2. In summer, Do not put this equipment in the sun directly.
3. Do not place the unit in the rain directly when used in the outdoor.
4. After using, press the power switch to turn off the power.
5. If the equipment is not used for a long time, please recharge the battery to at least 80% of its full level to lengthen the battery life.



	<p><i>CAUTION: RISK OF EXPLOSION IF THE BATTERY IS REPLACED BY AN INCORRECT TYPE. BATTERY INSTALLATION AND REPLACEMENT MUST BE CARRIED OUT BY PERSONNEL IN POSSESSION OF ENOUGH TECHNICAL KNOWLEDGE, EXPERIENCE OR INSTRUCTIONS TO BE ABLE TO PROPERLY PERFORM THE CONNECTIONS.</i></p> <p><i>DONOT USE THIS PRODUCT IN CLOSE PROXIMITY TO WATER. DO NOT USE THIS PRODUCT NEAR ANY HEAT SOURCE AND KEEP IT AWAY FROM NAKED FLAMES.</i></p>	 <p>UN3481 xxx xxx-xxxxxx</p>
---	--	---

TABLE OF CONTENTS

1. IMPORTANT SAFETY INFORMATION	1
2. FEATURES	2
3. CONTROL ELEMENTS	3
4. RECEIVER (RX) OPTIONAL	7
5. TRANSMITTER (TX)	9
6. CABINET POSITIONS	13
7. CONNECTING DIAGRAM	14
8. WIRE CONNECTIONS	16
9. TECHNICAL SPECIFICATIONS	17
10. BLOCK DIAGRAM	18
11. ACCESSORIES	19
12. CAUTION	19

SAFETY RELATED SYMBOLS



This symbol, wherever used, alerts you to the presence of un-insulated and dangerous voltages within the product enclosure. These are voltages that may be sufficient to constitute the risk of electric shock or death.



This symbol, wherever used, alerts you to important operating and maintenance instructions. Please read.

⊕ Protective Ground Terminal

~ AC mains (Alternating Current)

⚡ Hazardous Live Terminal

ON: Denotes the product is turned on.

OFF: Denotes the product is turned off.

WARNING

Describes precautions that should be observed to prevent the possibility of death or injury to the user.



Disposing of this product should not be placed in municipal waste and should be separate collection.

CAUTION

Describes precautions that should be observed to prevent damage to the product.

WARNING

• Power Supply

Ensure that the mains source voltage (AC outlet) matches the voltage rating of the product. Failure to do so could result in damage to the product and possibly the user.

Unplug the product before electrical storms occur and when unused for long periods of time to reduce the risk of electric shock or fire.

• External Connection

Always use proper ready-made insulated mains cabling (power cord). Failure to do so could result in shock/death or fire. If in doubt, seek advice from a registered electrician.

• Do Not Remove Any Covers

Within the product are areas where high voltages may present. To reduce the risk of electric shock do not remove any covers unless the AC mains power cord is removed.

Covers should be removed by qualified service personnel only.

No user serviceable parts inside.

• Fuse

To prevent fire and damage to the product, use only the recommended fuse type as indicated in this manual. Do not short-circuit the fuse holder. Before replacing the fuse, make sure that the product is OFF and disconnected from the AC outlet.

• Protective Ground

Before turning the product ON, make sure that it is connected to Ground. This is to prevent the risk of electric shock.

Never cut internal or external Ground wires. Likewise, never remove Ground wiring from the Protective Ground Terminal.

• Operating Conditions

Always install in accordance with the manufacturer's instructions.

To avoid the risk of electric shock and damage, do not subject this product to any liquid/rain or moisture. Do not use this product when in close proximity to water.

Do not install this product near any direct heat source. Do not block areas of ventilation. Failure to do so could result in fire.

Keep product away from naked flames.

IMPORTANT SAFETY INSTRUCTIONS

Read these instructions

Follow all instructions

Keep these instructions. Do not discard.

Heed all warnings.

Only use attachments/accessories specified by the manufacturer.

• Power Cord and Plug

Do not tamper with the power cord or plug. These are designed for your safety.

Do not remove Ground connections!

If the plug does not fit your AC outlet seek advice from a qualified electrician.

Protect the power cord and plug from any physical stress to avoid risk of electric shock.

Do not place heavy objects on the power cord. This could cause electric shock or fire.

• Cleaning

When required, either blow off dust from the product or use a dry cloth.

Do not use any solvents such as Benzol or Alcohol.

For safety, keep product clean and free from dust.

• Servicing

Refer all servicing to qualified service personnel only. Do not perform any servicing other than those instructions contained within the User's Manual.

10. BLOCK DIAGRAM

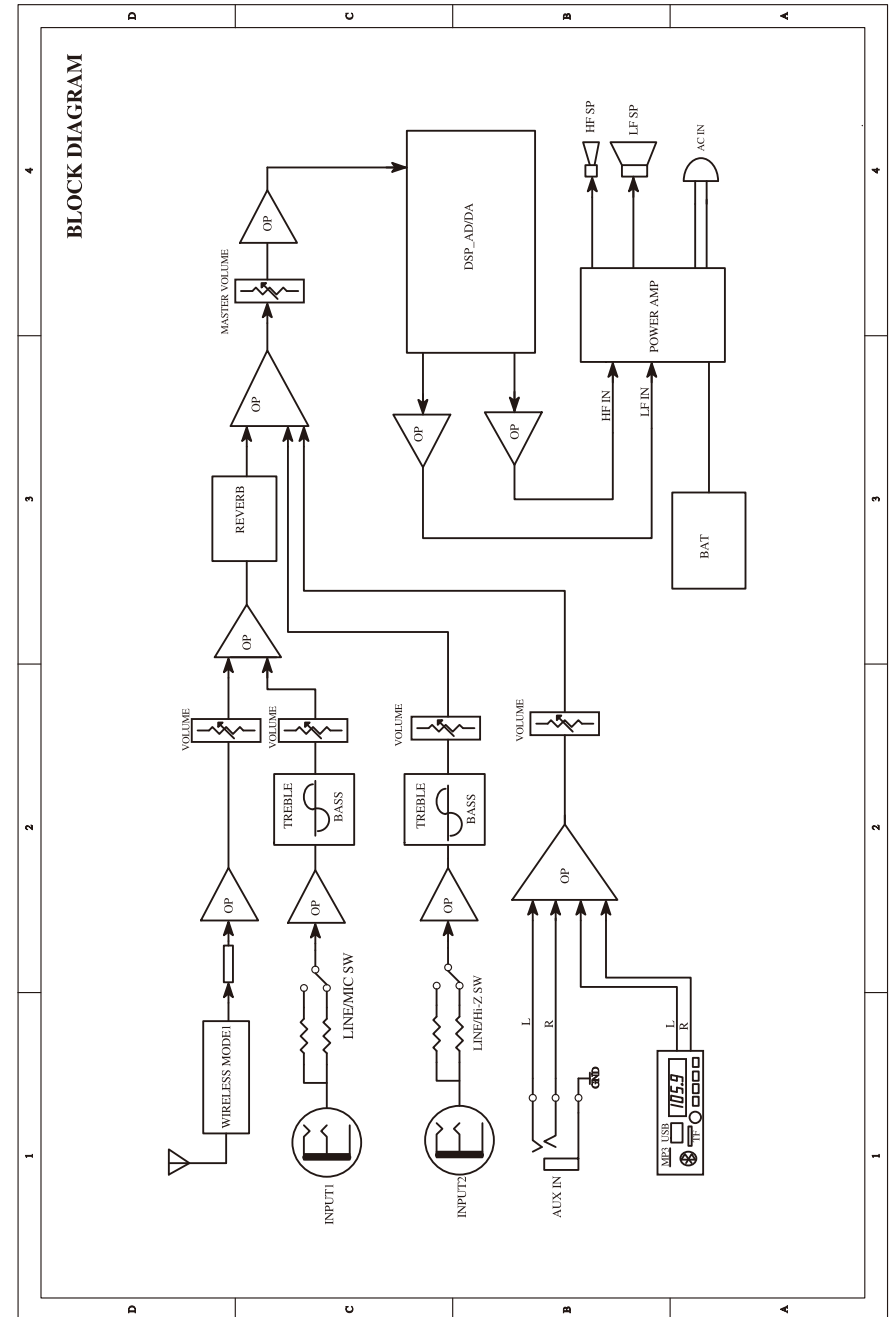

9. TECHNICAL SPECIFICATIONS

Items	Model	6.5" All-In One PA system
Wireless Frequency		UHF(470~900)MHZ
Bands		Dependent on applicable country regulations
Power Supply		AC:100V/110-240V/ Battery:25.9V(lithium)
System Type		2-Way Active All-in-one PA system
Transducer Low		6.5" Woofer
Transducer High		1" Neodymium driver
Frequency Response(-6dB)		70Hz-16KHz
Crossover Frequency		1.9KHz
Max SPL		116dB Max
AMP Power Output		Bi-amp, Class D 100W RMS total(LF 90W/HF 10W)
Input sensitivity		CH1 MIC:-35dBu(±1dBu) CH2 LINE:0dBu(± 1dBu) CH1 LINE:0dBu(±1dBu) CH2 Hi-Z:-35dBu(±1dBu) AUX:-10dBu(±1dBu)
Equalizer Controls		BASS:±10dB(at 100Hz)/HIGH:±10dBu(at 10KHz)
External Controls		Master Volume Controls : MIC&LINE Switch : Hi-Z&LINE Switch; AUX each Volume Controls; Volcepriority Switch;Power Indicators;Recharged Indicators; BatteryLevel Indicators; Reverb Level Volume;
Connectors		1x XLR/6.3 mm jack combo line/Mic input with 2 bands EQ 1x 6.3 mm jack line/Hi-Z input with 2 bands EQ 1x 3.5mm stereo jack input 1x 6.3 mm jack line mix output
Voice Priority		MIC1 and Wireless
Battery charge time		At least 4 hours
Battery ues time		More than 6 hours (Regular Play)
Built-in player		MP3 and Bluetooth
Enclosure Construction		Plastic cabinet, Trapezoidal,Metal grille, plastic handle.
Mounting		35MM standard pole-mount
Dimensions(LxWxH)		265(L)x240(W)x322.8(H)mm
Net Weight		5.8(KG)
Volume		1.85CFT

2. FEATURES

- User- friendly operation.
- Portable multifunctional active speaker
Multi-position PA system support flat placement with multiple purposes; Monitor, Tilt and bracket can be applied to personal entertainment, teaching system, DJ, etc.; light weight, easy to carry
- Bluetooth receiving function / MP3 player
- Rechargeable battery, can play continuously for 6 hours
- 3CH mixer, reverb, 2bands EQ
- 1CH / 2CH can be equipped with UHF wireless system (optional)
- Two power supplies: AC 100V/110-240V, DC25.9V (**LITHIUM BATTERY**)
- When AC works, Power LED lights up; when battery works, Power LED and battery level LED light up.
- When AC inputs, the battery will charge automatically, and Recharge indicator will light red. After full recharged, the indicator will light green.
- When battery is available, it will indicate low voltage and red LED of battery will light up.

AUTO standby function

- When there is no signal input or the input signal is all turned off, that is, the SIGNAL LED does not flash and stays for about 10 minutes, the power amplifier automatically enters the standby state, reducing standby power consumption and extending battery life;
- Enter the working state automatically from the standby: the main volume and the corresponding channel volume are not completely turned off, and the input signal can trigger the SIGNAL LED to flash, then the AMP immediately starts to enter the working state;

3. CONTROL ELEMENTS

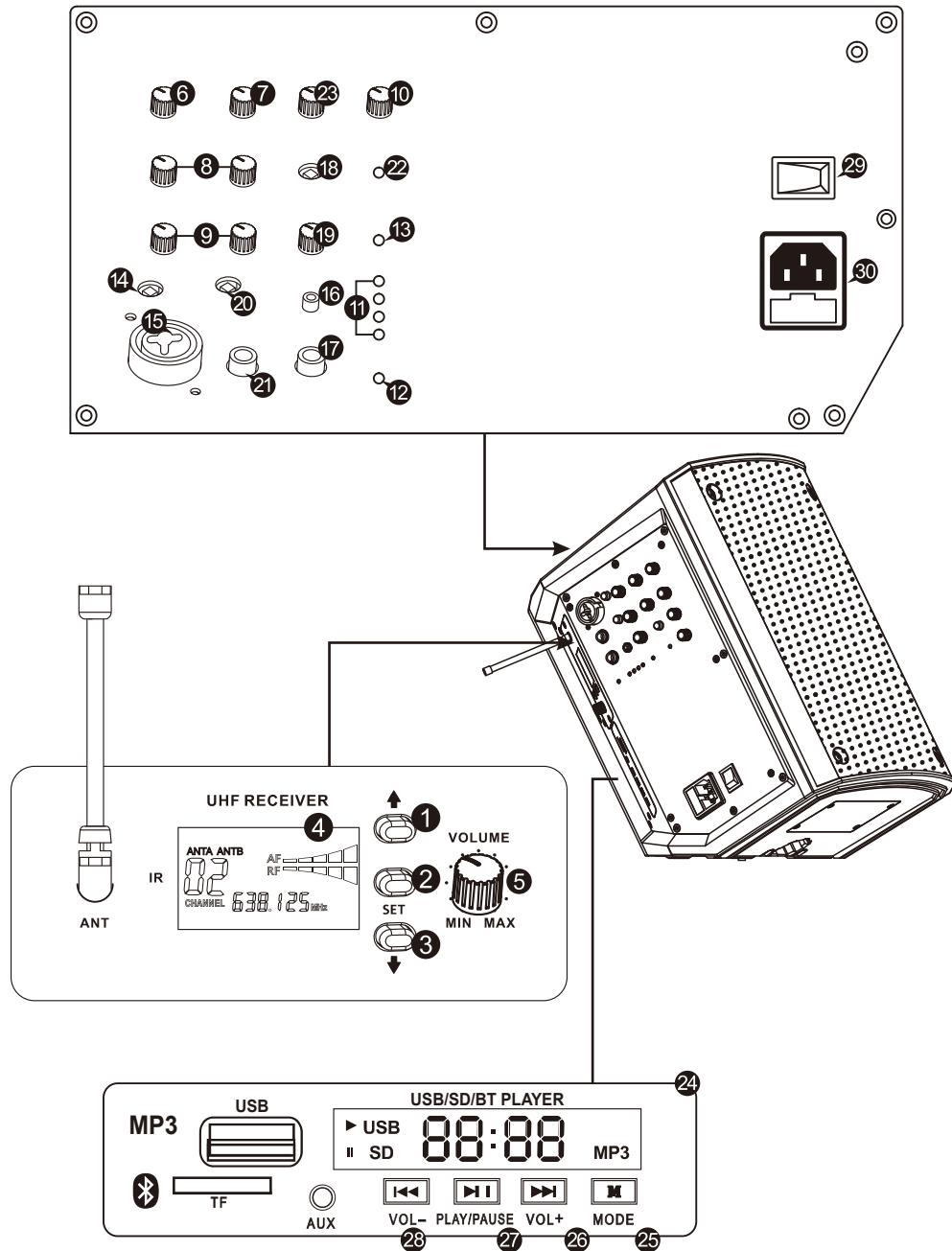

8. WIRE CONNECTIONS

Both connectors, 1/4" XLR or TRS, can be wired in balanced or unbalanced way, depending on the work necessity. The following ones are examples of how these connectors can be wired:

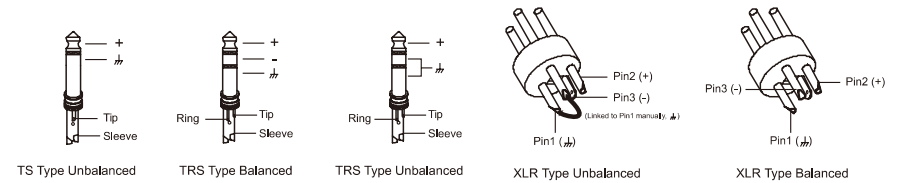

For Active Speaker Cabinets

As to these circumstances, audio connections is mostly intended for the signal flow, so, determine the wire configuration according to your real application system and its connecting facility. Normally, you have the following choices:

• Balanced

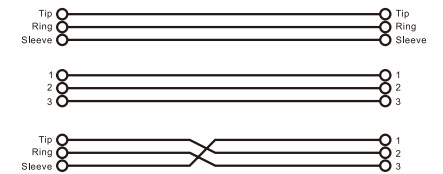
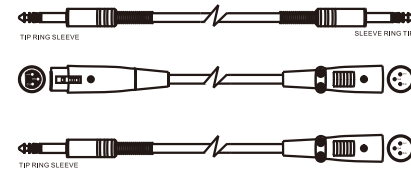

• Unbalanced

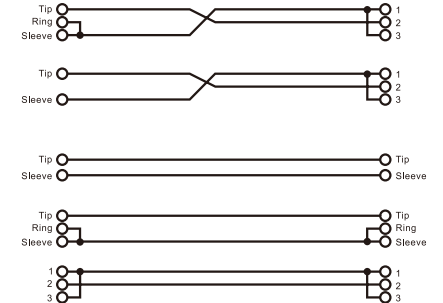
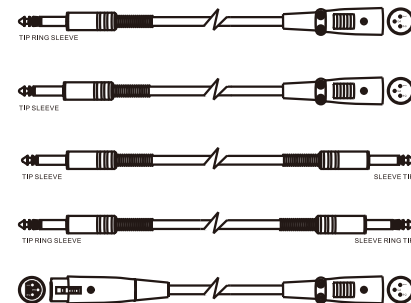

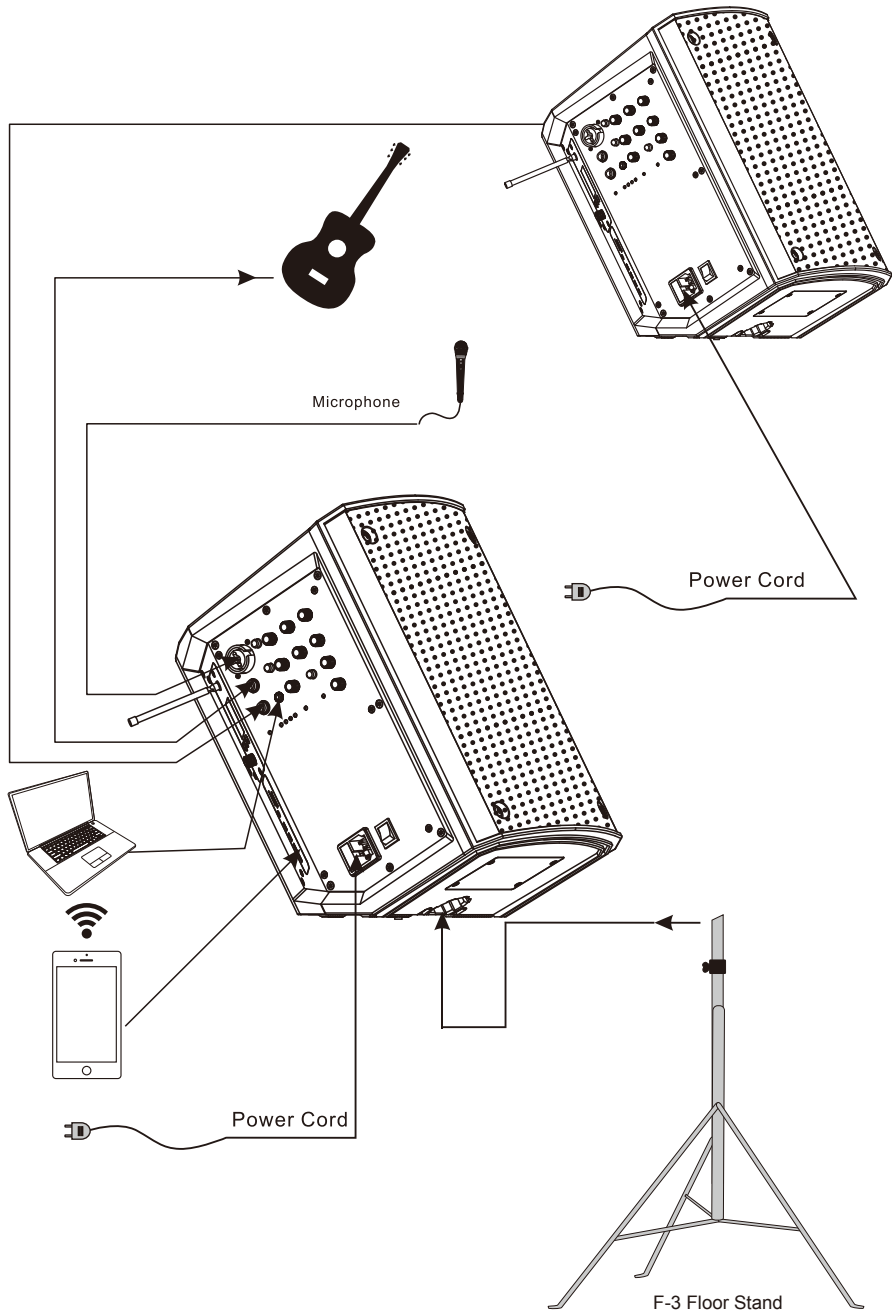

Microphone Receiver

- ① **UP**
Press this key to search for a channel number.
- ② **SET**
Press this key to adjust parameters inside the receiver.
- ③ **DOWN**
Press this key to search for a channel number.
- ④ **Display**
Here displayed channel and signal information for radio frequency(RF) and audio level(AF).
- ⑤ **Volume control**
Adjusts the level of the microphone signal.

Mixer

- ⑥ **Channel 1 Volume Control**
Controls the input signal level of channel 1.
- ⑦ **Channel 2 Volume Control**
Controls the input signal level of channel 2.
- ⑧ **Treble Control**
This knob adjusts the gain or attenuation of the channel's high section at $\pm 10\text{dB}$.
- ⑨ **Bass Control**
This knob adjusts the gain or attenuation of the bass section of the channel at $\pm 10\text{dB}$.
- ⑩ **Master Control**
This control adjusts the overall volume of the mixer and affects ALL channels.
- ⑪ **Battery Status Bar**
This bar of leds indicates the level of the battery charge.

Battery Level	☐ 🔋
○ 3x4	> 75%
○ 2x3	50%-75%
○ 1x2	25%-49%
○ LOWx1	< 10%

- ⑫ **Recharge Indicator**
This light turns red when the battery needs to be recharged and green when the battery is fully charged.
- ⑬ **Power Indicator**
This light will illuminate when the unit has been turned on.
- ⑭ **Line/Microphone Selector Channel 1**
This switch changes the impedance of the Line level channel or Microphone level.
- ⑮ **Channel 1 Input Connector**
This combo jack has XLR and TRS configuration(Balanced and unbalanced).
- ⑯ **Aux input**
This 1/8"(3.5mm)connector is the auxiliary channel input connector.
- ⑰ **Mix Output(Link)**
This TRS jack is the mixer output connector that is used to send signal to another active cabinet or to add a sub-bass.

⑩ **Priority Selector**

Pressing this selector will give output priority to the microphone connected on channel 1 over all other channels.

⑪ **Aux/MP3/Bluetooth Volume Control**

This control adjusts the signal level coming from the Aux channel or MP3 music player or Bluetooth.

⑫ **Line Selector/Hi-Z Channel 2**

This switch changes the impedance of the Line level channel or High Impedance level.

⑬ **Channel 2 Input Connector**

This TRS jack receives the input signal, either in high impedance or line level (Balanced/Unbalanced).

⑭ **Signal/Clip Indicator**

This light will illuminate when there is a signal on any channel in green. When the signal is very high and saturates the input, the color changes to red (Clip).

NOTE: Reduce the input level of the corresponding channel, when this led lights up red to avoid the "clip"

⑮ **Reverb Control**

This is the overall reverb effect control that applies to both the microphone and musical instruments.

MP3 and Bluetooth Player

⑯ **MP3/Bluetooth Module**

This is the music player control module.

⑰ **Mode Button**

Short press this button to select between USB/TF card/Aux and Bluetooth. USB/TF and auxiliary functions are automatically selected when inserting the device or if several devices are connected at the same time, one of them, must be selected manually. For BT mode, search in your mobile phone, computer and other devices for "VIRE BT" network, and then click, after connecting successfully, you can play music.

After the Bluetooth connection, the battery level displayed by the device is not used as a reference, please refer to the actual battery level displayed by the speaker.

Please note that the above modes can only use one mode at a time, and it is impossible to use more than two modes at the same time.

⑱ **Volume Button (VOL+)**

In MP3 or Bluetooth mode, if this button is pressed quickly it will change to the next song and if it is kept pressed it will increase the volume of the player

In Auxiliary mode it only works as a volume control, press and hold to increase.

⑲ **Play/Pause**

In MP3 mode, press this button to start playing the song, press again to pause the song.

In Auxiliary mode, press the button to enter "MUTE" mode.

In BT mode, press this button to start playing the song, press again to pause the song.

When you receive a call, press this button to answer and when you finish talking, press again to end the call.

7. CONNECTING DIAGRAM

Active, Full-range, two speakers. It is similar to the passive example but you do not need a power amplifier between the mixer and the two 6.5" speakers. Make all initial connections with all the equipments powered off, and ensure that all the main volume controls are turned down completely.

- Connect one side of the signal cable at your mixer into the Output Left/Right (with Stereo Jack or XLR) and the other side of the cable into the Line Input (COMBO) of your active speaker cabinet (with Stereo Jack or XLR).
- Connect the power cord to main.
- Turn ON your mixer first, then the active speaker cabinets.
- Turn up the volume control of the cabinets.
- Use PEL function to get the proper input level for the mixer, and adjust the Main Mix Level control to reach the desired output level.
- After use, turn off your active speaker cabinets first, then the mixer.

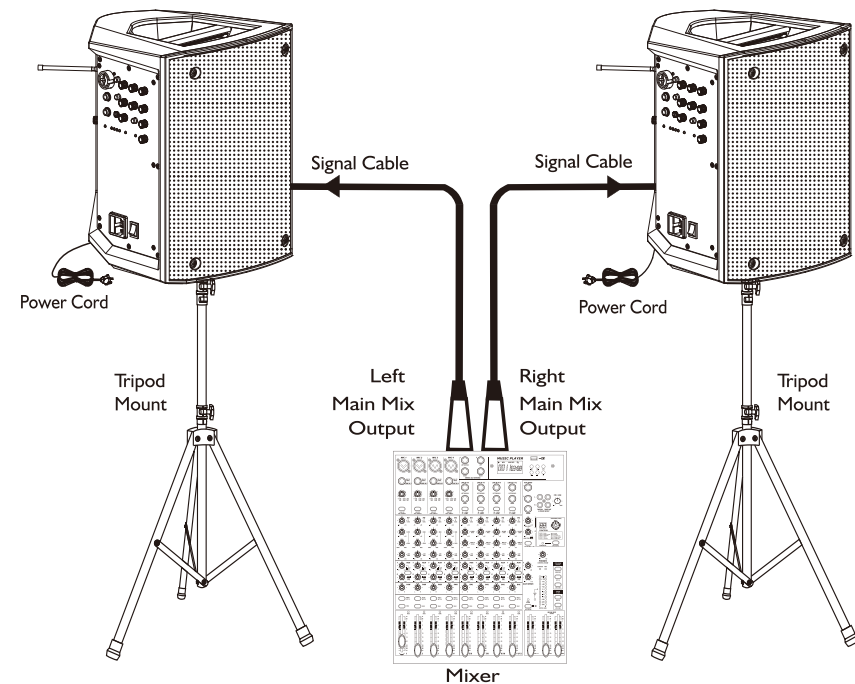

6.CABINET POSITIONS

This multifunctional and portable cabinet has three modes of operation and sound projection depending on the application and the place where you work. Thanks to internal switches and equalizers, the system changes the response curve automatically to maintain optimum balance in each position.

Elevated Surface

Place the speaker on a raised surface or on a speaker stand. This position allows greater projection of sound in full range to the audience.

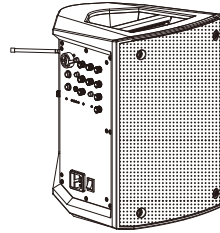

Inclined

This position is especially used when both the artist and the audience are standing and in a close-up shot or when the audience is sitting in a shot in which the cabinet radiates sound directly to them. In addition, the artist will also have a good reference of what he is playing and singing.

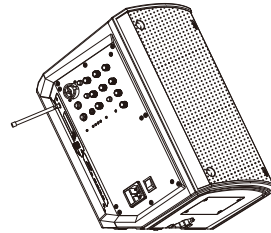

Monitor

this cabinet has the option of being used as a floor monitor or for a DJ, by tilting it sideways.

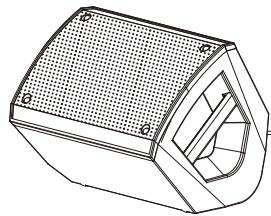

⑳ Volume Button(VOL-)

In MP3 or Bluetooth mode, if this button is pressed quickly, it will change to the previous song and if it is kept pressed it will decrease the volume of the player.

In Auxiliary mode it only works as a volume control, press and hold to decrease it.

㉑ Power Switch

If this switch is set to the ON position, both the AC and DC will be connected, although the AC will take priority over the DC. When AC is not present at the power input, the DC power source will automatically switch to keep the unit working. If this switch is in the OFF position, the entire unit will stop working. If the switch is in the recharge position, the internal battery will recharge, but the unit will not work.

㉒ Main AC Input

Check the voltage available in your country and how the voltage of your unit is configured, before trying to connect it to the main AC. 100V/50-60Hz, 110-240V/50-60Hz.

4. RECEIVER(RX)OPTIONAL

•Display interface

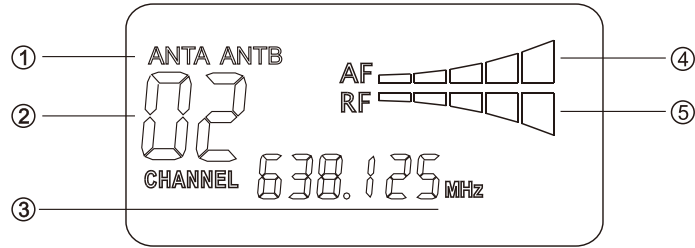

- ① CHA/CHB
- ② Frequency code
- ③ Frequency display
- ④ AF power indicator
- ⑤ RF power indicator

•Single channel

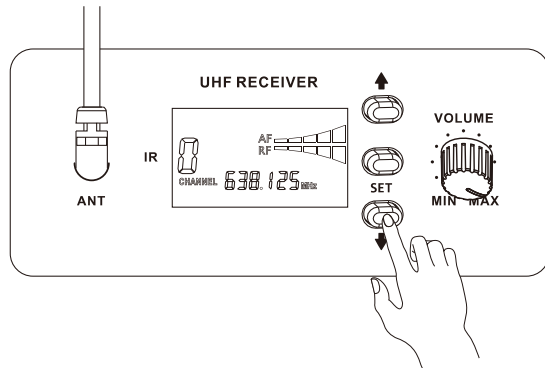

•Double channel

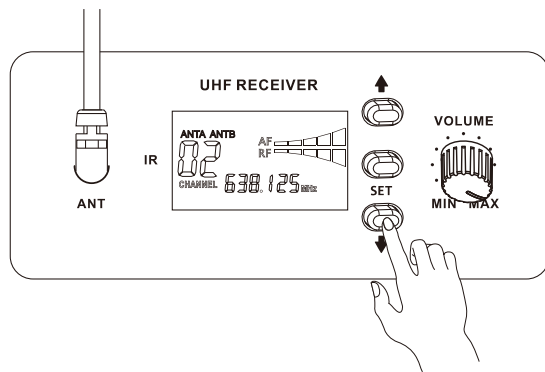

HOW TO PAIR YOUR RECEIVER AND TRANSMITTER

Power on your receiver, Then select the channel you like or scan the cleanest channel automatically according to above steps. Then quick the “SET” button and release it to enter pair mode. Power on your transmitter, Then place the IR port of receiver to face towards the IR lens of transmitter within 20cm distance. Once TX and RX are paired successfully. The RF/AF indicator on receiver will light solid.

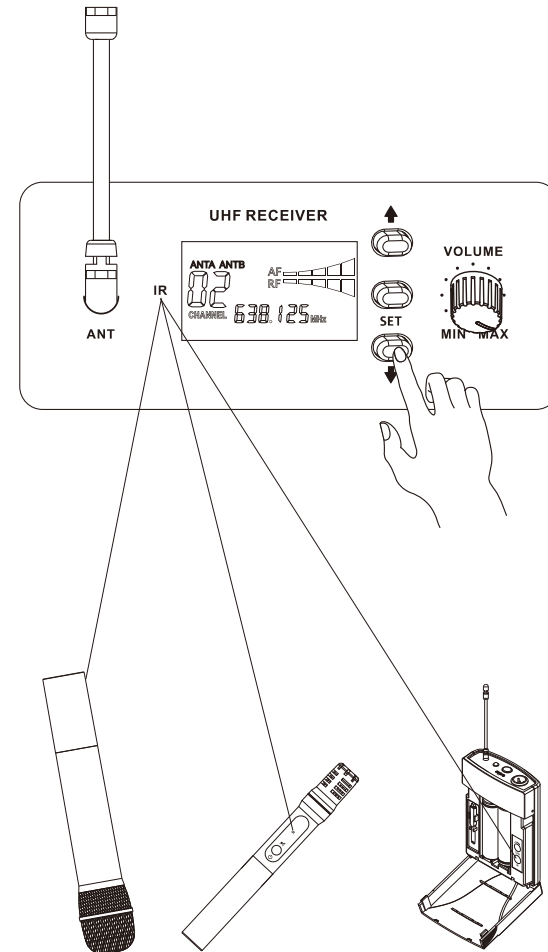

- ⓑ Pin 2: "Phantom Power" for condenser microphones
- ⓒ Pin 3: Designed for musical instruments (When used with cable)
- ⓓ Pin 4: Desugbed for use with dynamic or condenser microphones

⑤ **Infrared(IR)**

This window is used to capture the infrared signal sent from the receiver. During IR adjustment to pair the transmitter with the receiver, the IR lens must face the receiver to load the selected channel.

⑥ **Gain Control**

This control adjusts the input sensitivity for working with microphones or musical instruments. to achieve a higher efficiency, adjust this gain where you can see the audio frequency bar (AF) on the receiver at 75%

⑦ **Screwdriver**

This unit includes a special tool to adjust the gain.

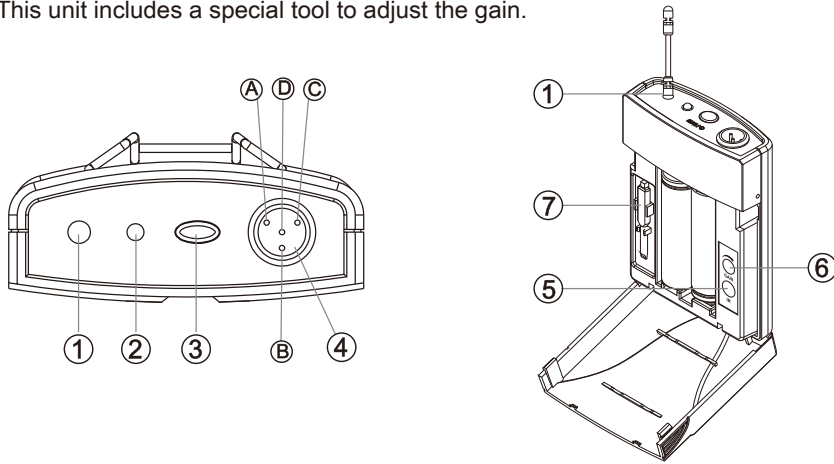

1. Press the "↓" or "↑" button on the front of the receiver to choose an available channel.
2. The channel number will increase from 0 to F (16 Channels).
3. If you hold press the "↑" button, the displayed channel will fast forward.
4. If you hold press the "↓" button, the displayed channel will fast reverse.
5. Briefly press the "SET" button, to select channels, ATN A and ATN B (CHA and CHB separately). (If your unit comes with a single channel, this function is not available to change the channel).
6. After selecting the channel (ATN A and ATN B), press and hold the "↓" button for 3 seconds, then the unit scans the full frequency and finally automatically picks the cleanest channel to pair between RX and TX.
7. Or after selecting the channel (ATN A and ATN B), press and hold the "↑" button for 3 seconds to enter the infrared pairing mode. Select the frequency by briefly pressing the "↓" or "↑" button and then continue the pairing between RX and TX by infrared transmission
8. Depending on the current selected channel (CHA or CHB), if the pairing between RX and TX is successful, the AF/RF indicator will show activity on the display.
9. This unit has an independent volume control for this receiver.

With the transmitter turned off, insert two standard AA(1.5V) batteries, making sure that the positive and negative polarity markings are oriented correctly. Although NI-CAD rechargeable batteries can be used, this transmitter cannot be recharged. Warning: do not insert the battery upside down or it may cause serious damage to your transmitter and will void the warranty.

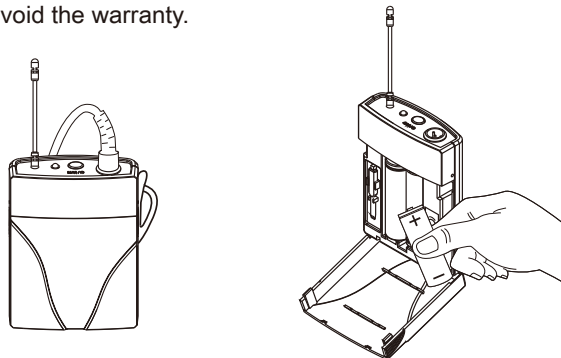

5. TRANSMITTER(TX)

There are three types of transmitters dedicated to our customer. Customer can select the transmitters according to their preferences.

Option#1 HANDHOLD TRANSMITTER

- ① **Protecton Grid**
- ② **Microphone Body**
- ③ **Battery Cover**

Insert two standard AA(1.5V) batteries here, making sure that the positive and negative polarity marks are oriented correctly, Although NI-CAD rechargeable batteries can be use, this transmitter cannot recharge them.

Warning: do not insert the battery upside down or it may cause serious damage to your transmitter and will void the warranty.

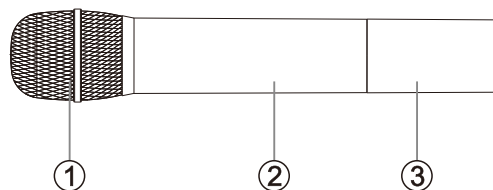

④ **Status Indicator**

This light shows the operation mode:

GREEN	Normal Operation
RED	Mute
Flashing RED	Low power

⑤ **Power/Mute Switch**

To turn on or off, keep this button pressed.

To enter "MUTE" mode press and release this button.

⑥ **Infrared(IR)**

This window is used to capture the infrared signal sent from the receiver. During IR adjustment to pair the transmitter with the receiver, the IR lens must face the receiver to load the selected channel.

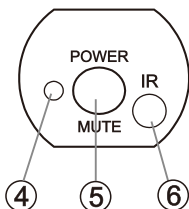

Option#2 PEN-SHAPE TRANSMITTER

① **Power/Mute button**

Press and hold for 3 seconds to turn the unit on or off, the indicator will light red firstly and change to light green after about 5 seconds. It enters normal operation mode.

② **Status indicator**

A quick press and release will mute or un-mute the transmitter when the transmitter turns on. It will light red for mute and green for un-mute.

③ **IR LENS**

The window is used to capture the infrared signal sent from receiver. During the IR SET to channelize the transmitter, the IR lens must face towards the receiver to load the selected channel.

④ **Battery cover**

Insert one standard AA(1.5V) battery here, Being sure the plus and minus polarity marking of battery are facing correctly. Although rechargeable NI-CAD battery can be used too, but the unit can't obtain adequate power to keep working for more than 4 hours. Warning: don't insert the battery backwards, Or it maybe cause severe damage to your transmitter and will void your warranty.

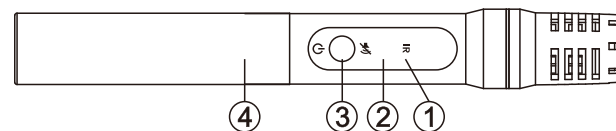

Option#3 BODY-PACK TRANSMITTER

① **Antenna**

This permanently attached transmitter antenna should be fully extended during normal operation.

② **Status Indicator**

This LED displays the operation mode:

GREEN	Normal Operation
RED	Mute
Flashing RED	Low power

③ **Power/Mute Switch**

Press and hold to turn the unit on or off.

Press and release to mute or unmute the transmitter.

④ **Mini 4P connector**

Ⓐ Pin 1:Ground(GND)