

PORTABLE SOUND SYSTEM WITH BLUETOOTH



NF05728-1.1

FCC STATEMENT

1. This device complies with Part 15 of the FCC Rules. Operation is subject to the following two conditions:
 - (1) This device may not cause harmful interference, and
 - (2) This device must accept any interference received, including interference that may cause undesired operation.
2. Changes or modifications not expressly approved by the party responsible for compliance could void the user's authority to operate the equipment.

Radiation Exposure Statement

This equipment complies with FCC radiation exposure limits set forth for an uncontrolled environment. This equipment should be installed and operated with minimum distance 20cm between the radiator & your body.

NOTE: This equipment has been tested and found to comply with the limits for a Class B digital device, pursuant to Part 15 of the FCC Rules. These limits are designed to provide reasonable protection against harmful interference in a residential installation. This equipment generates, uses and can radiate radio frequency energy and, if not installed and used in accordance with the instructions, may cause harmful interference to radio communications. However, there is no guarantee that interference will not occur in a particular installation. If this equipment does cause harmful interference to radio or television reception, which can be determined by turning the equipment off and on, the user is encouraged to try to correct the interference by one or more of the following measures:

- Reorient or relocate the receiving antenna.
- Increase the separation between the equipment and receiver.
- Connect the equipment into an outlet on a circuit different from that to which the receiver is connected.
- Consult the dealer or an experienced radio/TV technician for help.

IMPORTANT!

Please read this manual carefully before operating this unit for the first time.

10. ACCESORIES

Power Cord	1
Wireless Microphone (optional)	1
User Manual	1
Battery (optional)	1
Power Adapter	1

11. CAUTION

- 1) 1. Do not use any volatile solvents such as toluene, Alcohol or gasoline for safety, keep product clean and free from dust.
- 2) In summer, Do not put this equipment in the sun directly.
- 3) Do not place the unit in the rain directly when used in the outdoor.
- 4) After using, press the power switch to turn off the power.
- 5) If the equipment is not used for a long time, please recharge the battery to at least 80% of its full level to lengthen the battery life.



CAUTION: RISK OF EXPLOSION IF THE BATTERY IS REPLACED BY A DIFFERENT TYPE. BATTERY INSTALLATION AND REPLACEMENT MUST BE PERFORMED BY PERSONNEL IN POSSESSION OF SUFFICIENT TECHNICAL KNOWLEDGE, EXPERIENCE, OR INSTRUCTIONS TO PROPERLY PERFORM CONNECTIONS. DO NOT USE THIS PRODUCT NEAR WATER. DO NOT USE THIS PRODUCT NEAR ANY SOURCE OF HEAT AND KEEP IT AWAY FROM FLAMES.



9. BLOCK DIAGRAM

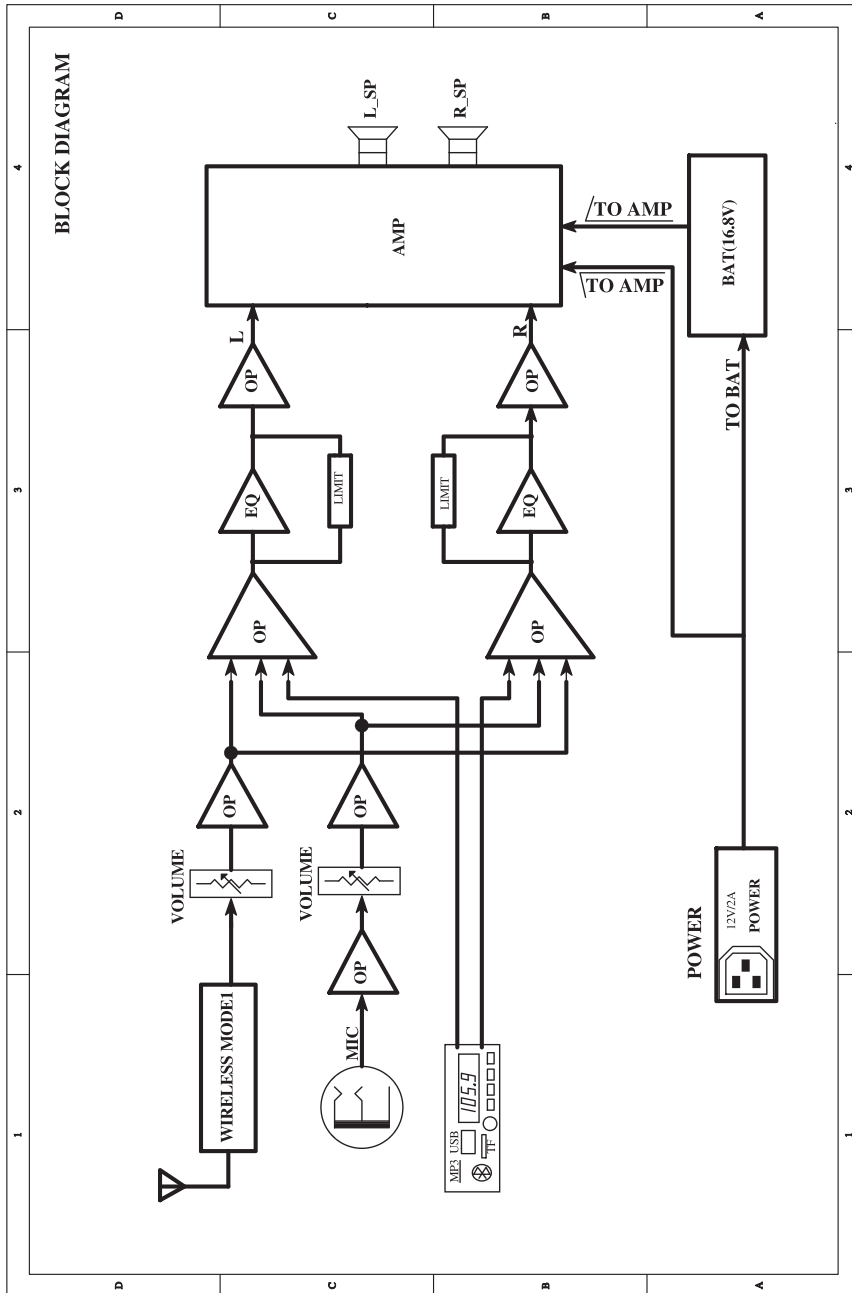

TABLE OF CONTENTS

1. IMPORTANT SAFETY INFORMATION	1
2. CONTROL ELEMENTS	2
3. RECEIVER (RX) OPTIONAL	6
4. TRANSMITTER (TX)	7
5. CABINET POSITIONS	11
6. CONNECTING DIAGRAM	12
7. WIRE CONNECTIONS	13
8. TECHNICAL SPECIFICATIONS	14
9. BLOCK DIAGRAM	15
10. ACCESSORIES	16
11. CAUTION	16

SAFETY RELATED SYMBOLS



This symbol, wherever used, alerts you to the presence of un-insulated and dangerous voltages within the product enclosure. These are voltages that may be sufficient to constitute the risk of electric shock or death.



This symbol, wherever used, alerts you to important operating and maintenance instructions. Please read.



Protective Ground Terminal



AC mains (Alternating Current)



Hazardous Live Terminal

ON: Denotes the product is turned on.

OFF: Denotes the product is turned off.

WARNING

Describes precautions that should be observed to prevent the possibility of death or injury to the user.



Disposing of this product should not be placed in municipal waste and should be separate collection.

CAUTION

Describes precautions that should be observed to prevent damage to the product.

WARNING

• Power Supply

Ensure that the mains source voltage (AC outlet) matches the voltage rating of the product. Failure to do so could result in damage to the product and possibly the user.

Unplug the product before electrical storms occur and when unused for long periods of time to reduce the risk of electric shock or fire.

• External Connection

Always use proper ready-made insulated mains cabling (power cord). Failure to do so could result in shock/death or fire. If in doubt, seek advice from a registered electrician.

• Do Not Remove Any Covers

Within the product are areas where high voltages may present. To reduce the risk of electric shock do not remove any covers unless the AC mains power cord is removed.

Covers should be removed by qualified service personnel only.

No user serviceable parts inside.

• Fuse

To prevent fire and damage to the product, use only the recommended fuse type as indicated in this manual. Do not short-circuit the fuse holder. Before replacing the fuse, make sure that the product is OFF and disconnected from the AC outlet.

• Protective Ground

Before turning the product ON, make sure that it is connected to Ground. This is to prevent the risk of electric shock.

Never cut internal or external Ground wires. Likewise, never remove Ground wiring from the Protective Ground Terminal.

• Operating Conditions

Always install in accordance with the manufacturer's instructions.

To avoid the risk of electric shock and damage, do not subject this product to any liquid/rain or moisture. Do not use this product when in close proximity to water.

Do not install this product near any direct heat source. Do not block areas of ventilation. Failure to do so could result in fire.

Keep product away from naked flames.

IMPORTANT SAFETY INSTRUCTIONS

Read these instructions

Follow all instructions

Keep these instructions. Do not discard.

Heed all warnings.

Only use attachments/accessories specified by the manufacturer.

• Power Cord and Plug

Do not tamper with the power cord or plug. These are designed for your safety.

Do not remove Ground connections!

If the plug does not fit your AC outlet seek advice from a qualified electrician.

Protect the power cord and plug from any physical stress to avoid risk of electric shock.

Do not place heavy objects on the power cord. This could cause electric shock or fire.

• Cleaning

When required, either blow off dust from the product or use a dry cloth.

Do not use any solvents such as Benzol or Alcohol.

For safety, keep product clean and free from dust.

• Servicing

Refer all servicing to qualified service personnel only. Do not perform any servicing other than those instructions contained within the User's Manual.

FEATURES

- Class D STEREO 20W RMS
- 3" Active Portable Speaker
- Rechargeable battery pack (Optional)
- 101 dB SPL MAX
- Bluetooth / SD / MP3 Player
- 1 ch UHF receiver (WR-1U)

8. TECHNICAL SPECIFICATIONS

Model	WS-2
System Type	3" Active Portable Speaker System
Power Amplification	Class-D 20W Continuous Power, 40W Program Power
Frequency Response	180Hz-15KHz (± 3 dB)
Frequency Range	150Hz-19KHz (-10dB)
Maximum SPL@1m	108dB
Transducer	2X3" Full Range Speaker
Built-in Player	Bluetooth / SD / MP3 Player / 1x3.5mm Stereo Input (BT 4mW MAX, Frequency Range:2402-2480MHz)
Connections	1 x ϕ 6.3 Line/Mic input
External Controls	Volume Control, Power switch with LED indicator, Recharge LED and Low Battery LED
Wirless (Optional)	Frequency: UHF (470-494), (542-566), (863-865)MHZ Bands: Dependent on Applicable Country Regulations Mic Band: UHF(470-900)MHZ WT-X Pen Wireless MIC or U899H or Head Mic (MIC 10mW MAX)
Battery Life (Optional)	Charge Time: At Least 6 Hours Use Time: Music Player more than 8 Hours (Normal)
Protection Features	Over-excursion, thermal, Digital Limtor.
AC Adaptor	Input: 100-240V ~ 50/60Hz with Switching Power Output: DC 15V \equiv 2A
Enclosure Construction	Plastic Cabinet, Portable, Metal Grille, Plastic Handle.
Dimension(H x W x D)	7.5"(190mm) x 10.1"(256mm) x 5.2"(131mm)
Net Weight	2.0Kg / 4.41 lbs

7. WIRE CONNECTIONS

Both connectors, 1/4" XLR or TRS, can be wired in balanced or unbalanced way, depending on the work necessity. The following ones are examples of how these connectors can be wired:

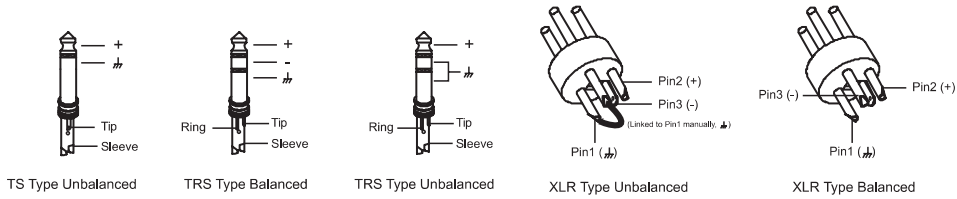

For Active Speaker Cabinets

As to these circumstances, audio connections is mostly intended for the signal flow, so, determine the wire configuration according to your real application system and its connecting facility. Normally, you have the following choices:

• Balanced

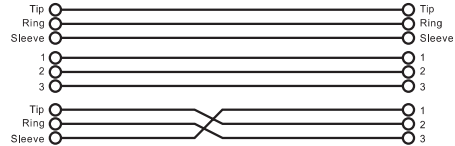
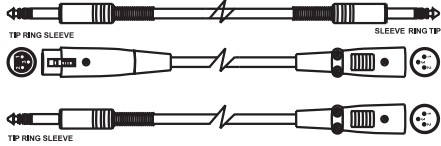

• Unbalanced

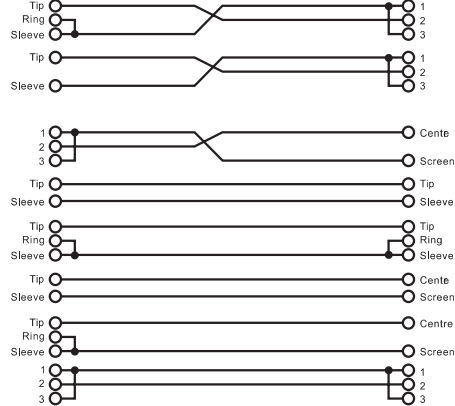
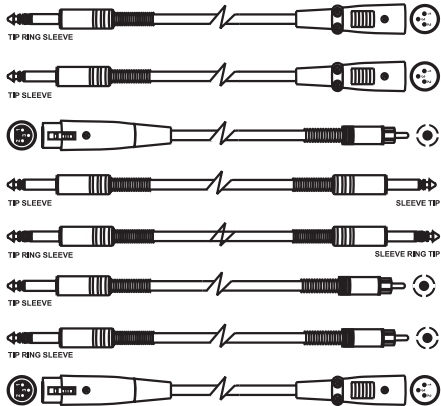

2. CONTROL ELEMENTS

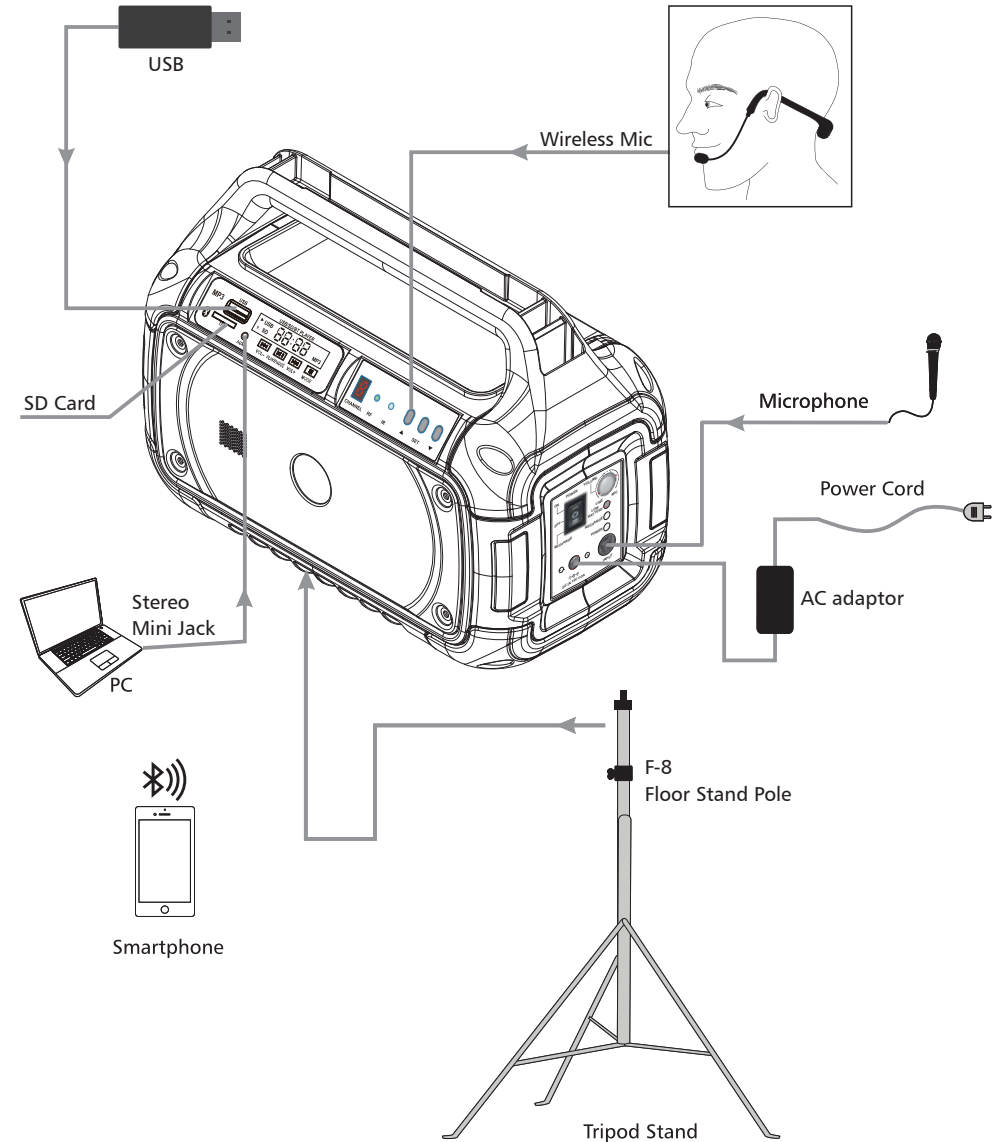

WS-2

WR-1U / WT-X / U-899H / U-899P + LM-60 / UDM-525 / WS-F



UDM-525
Wired Microphone

FREQUENCY RESPONSE CURVE

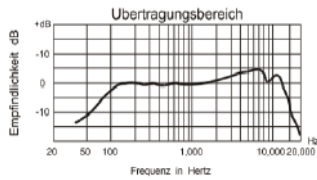

TECHNICAL SPECIFICATION

Model	UDM-525
Type	Moving coil dynamic microphone
Characteristics	Uni-directional
Impedance	600 Ohm ± 30% at 1000 Hz
Sensitivity	-74 ± 3dB AT 1000 Hz
Frequency Response	70-14,000 Hz
Cable	5.5mm x 15 Feet with 6.3mm Phone plug
Weight	310 Grams without cable and box

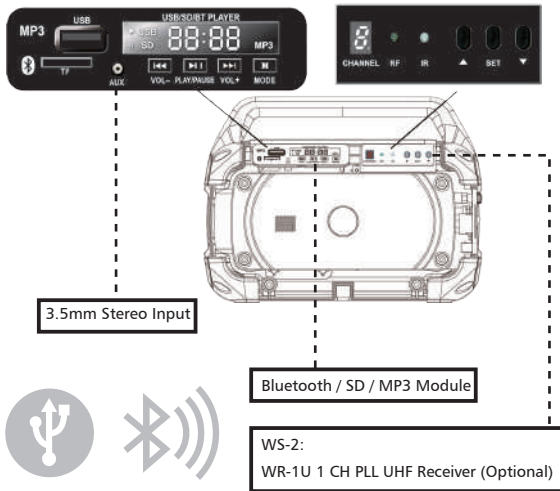

U-899P+LM-60 WT-X U-899H
Wireless Microphone

6.CONNECTING DIAGRAM

Make your initial connections with all the equipment powered off, and ensure that all the main volume controls are turned down completely.

For Full Range Stereo System

- 1) Connect one side of the signal cable at your mixer into the Output Left/ Right (with Stereo Jack or XLR) and the other side of the cable into the Line Input (COMBO) of your active speaker cabinet (with 1/8" or 1/4" Line Input).
- 2) Connect the power cord to main.
- 3) Turn ON your mixer first, then the active speaker cabinets.
- 4) Turn up the volume control of the cabinets.
- 5) Use PFL function to get the proper input level for the mixer, and adjust the Main Mix Level control to reach the desired output level.
- 6) After use, turn off your active speaker cabinets first, then the mixer.

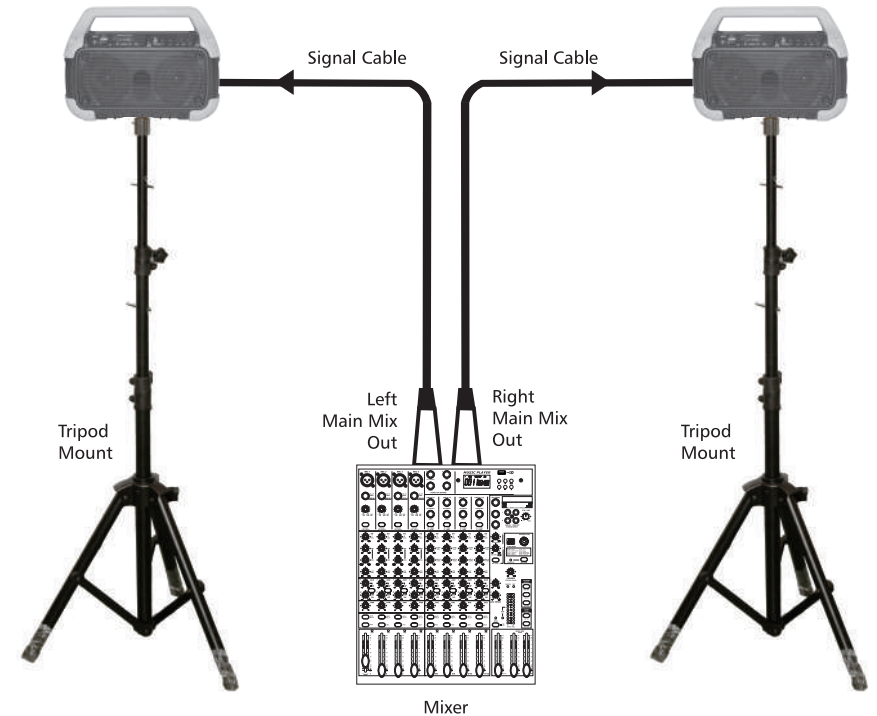

5. CABINET POSITIONS

1 - Multifunctional Portable Design

Complete functions, including MP3/SD/BT/wireless mic, rechargeable, stereo design, easy to carry, can meet the needs of teaching, conferences, etc.



1

2 - Bracket function (optional)

Optional bracket function to meet the needs of various places, such as small meeting rooms, multimedia classrooms, etc.



2

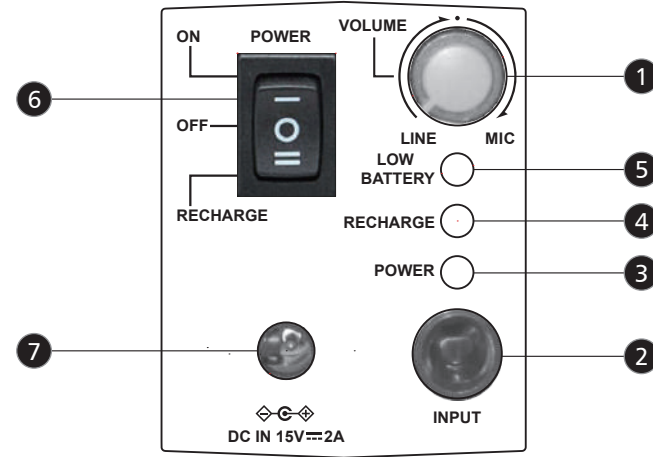

1) LINE/MIC Volume Control

This control adjusts the signal level coming from the LINE/MIC channel.

2) LINE/MIC input:

This 1/4 "(6.3mm) connector is the LINE/MIC channel input connector.

3) Power Indicator

This light will illuminate when the unit has been turned on.

4) Recharge Indicator

This light turns red when the battery needs to be recharged and green when the battery is fully charged.

5) Low battery Indicator

When the Low Battery lights up, it means that the battery is about to run out. Please connect the AC Power adapter to charge the battery in time.

6) Power Switch

If this switch is set to the ON position, both the AC and DC will be connected, although the AC will take priority over the DC. When AC is not present at the power input, the DC power source will automatically switch to keep the unit working. If this switch is in the OFF position, the entire unit will stop working. If the switch is in the recharge position, the internal battery will recharge, but the unit will not work.

7) DC IN

Plug the supplied AC adaptor into the DC IN to charge the batteries. The adaptor can also be used as the power supply.

Note: when not in use, do not charge batteries for longer than 10 Hours

Microphone Receiver

8) Digital display

Display frequency code and volume level

9) RF Indicator

When the RF light is on, it means that the RF signal from TX has been successfully

10) Received IR indicator

IR port of receiver is used to pair with TX

11) UP button

Press and release it to increase channel code number or volume level.

12) SET button

Press and release it to switch interface between CH and VOL.

13) DOWN button

Press and release it to decrease channel code number or volume level.

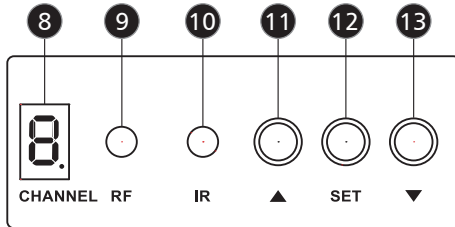

MP3 and Bluetooth Player

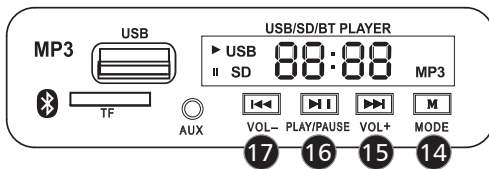

14) Mode Button

Short press this button to select between USB / TF card / Aux and Bluetooth. USB / TF and auxiliary functions are automatically selected when inserting the device or if several devices are connected at the same time, one of them, must be selected manually.

For BT mode, search in your mobile phone, computer and other devices for "VIRE BT" network, and then click, after connecting successfully, you can play music.

After the Bluetooth connection, the battery level displayed by the device is not used as a reference, please refer to the actual battery level displayed by the speaker.

Please note that the above modes can only use one mode at a time, and it is impossible to use more than two modes at the same time.

How to pair your receiver and transmitter

Power on your receiver, press and release the UP or DOWN button to select the channel code you prefer manually, Then press and hold the UP button to enter pairing mode, while press and hold DOWN button, it not only enters pairing mode but also find the cleanest channel by automatic scanning. Power on your transmitter, Then place the IR port of receiver to face towards the IR lens of transmitter within 20 CM distance. Once TX and RX are paired successfully. the RF indicator on receiver will light solid.

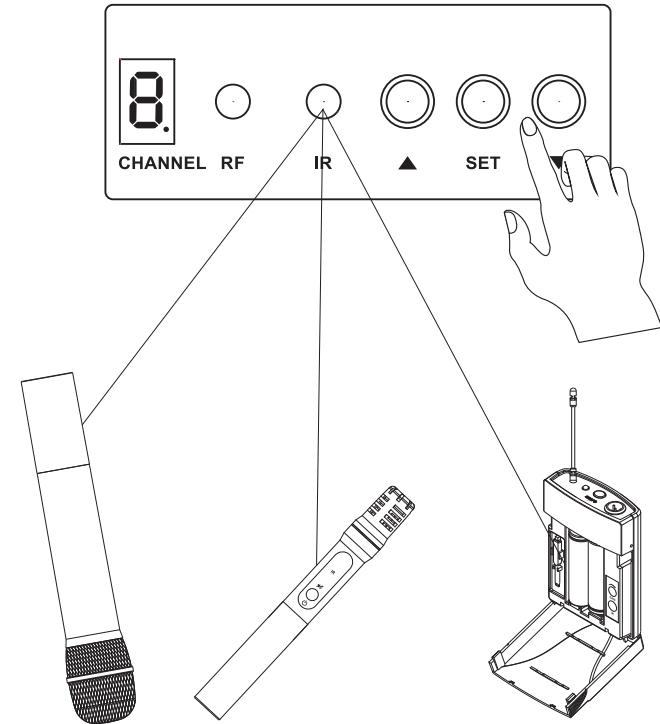

6) Gain Control

This control adjusts the input sensitivity for working with microphones or musical instruments. To achieve a higher efficiency, adjust this gain where you can see the audio frequency bar (AF) on the receiver at 75%

7) Screwdriver

This unit includes a special tool to adjust the gain.

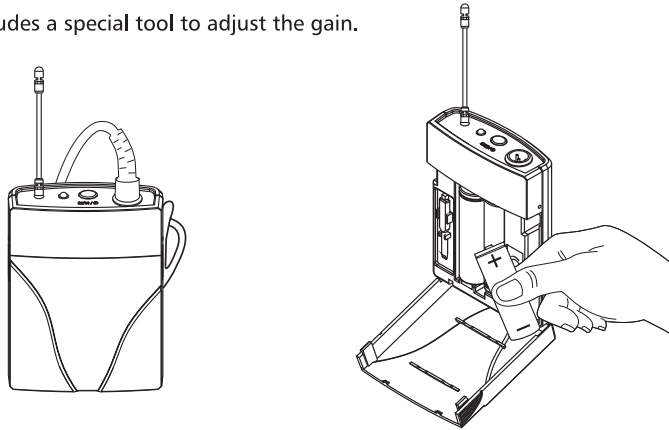

With the transmitter turned off, insert two standard AA (1.5V) batteries, making sure that the positive and negative polarity markings are oriented correctly. Although NI-CAD rechargeable batteries can be used, this transmitter cannot be recharged. Warning: do not insert the battery upside down or it may cause serious damage to your transmitter and will void the warranty.

15) Volume Button (VOL +)

In MP3 or Bluetooth mode, if this button is pressed quickly it will change to the next song and if it is kept pressed it will increase the volume of the player
In Auxiliary mode it only works as a volume control, press and hold to increase.

16) Play / Pause

In MP3 mode, press this button to start playing the song, press again to pause the song.
In Auxiliary mode, press the button to enter "MUTE" mode.
In BT mode, press this button to start playing the song, press again to pause the song. When you receive a call, press this button to answer and when you finish talking, press again to end the call.

17) Volume Button (VOL-)

In MP3 or Bluetooth mode, if this button is pressed quickly, it will change to the previous song and if it is kept pressed it will decrease the volume of the player.
In Auxiliary mode it only works as a volume control, press and hold to decrease it.

3. RECEIVER(RX)OPTIONAL

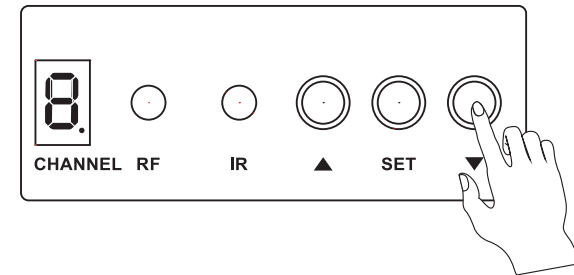

1. SET button: press and release the button to switch interface from CH to volume. Enter CH interface, digital light (only figure 8)will light up. Enter Volume interface, digital light (both figure 8 and decimal point) will light up simultaneously.

2. UP button: under CH interface, press and release the button to increase channel code number. you can select the channel you perfect .Press and hold the button to enter pairing mode, the digital light begins to flash ,Once TX is paired RX successfully, the green LED will light and the digital light stops flashing.
Under volume interface, press and release the button to increase volume, you can select the suitable volume by this way.

3. Down button: under CH interface, press and release the button to decrease channel code number . Press and hold the button to enter pairing mode, it will scan all channels automatically to select the cleanest channel for pairing, the digital light begins to flash ,Once TX is paired RX successfully, the green LED will light, the digital light stops flashing.
Under volume interface, press and release the button to reduce volume, you can select suitable volume by this way.

4. TRANSMITTER (TX)

Topp Pro offers three transmitter options to be chosen by the user according to what is most convenient for them.

Option #1

Handheld Transmitter

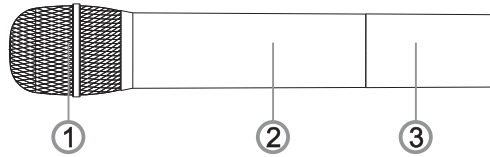

- 1) Protection Grid
- 2) Microphone Body
- 3) Battery Cover

Insert two standard AA (1.5V) batteries here, making sure that the positive and negative polarity marks are oriented correctly. Although NI-CAD rechargeable batteries can be used, this transmitter cannot recharge them.

Warning: do not insert the battery upside down or it may cause serious damage to your transmitter and will void the warranty.

4) Status Indicator

This light shows the operation mode:

GREEN	Normal operation
RED	"MUTE"
Flashing RED	Low power

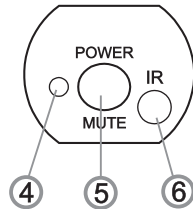

5) Power / Mute Switch

To turn on or off, keep this button pressed. To enter "MUTE" mode press and release this button.

6) Infrared (IR)

This window is used to capture the infrared signal sent from the receiver. During IR adjustment to pair the transmitter with the receiver, the IR lens must face the receiver to load the selected channel.

Option #2

PEN-SHAPE TRANSMITTER

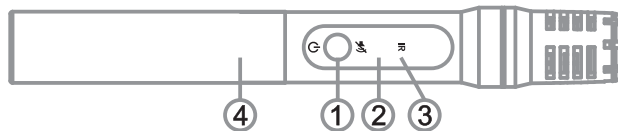

1) Power/Mute button

Press and hold for 3 seconds to turn the unit on or off, the indicator will light red first and change to light green after about 5 seconds. It enters normal operation mode.

2) Status indicator

A quick press and release will mute or un-mute the transmitter when the transmitter turns on. It will light red for mute and green for un-mute.

3) IR LENS

The window is used to capture the infrared signal sent from receiver. During the IR SET to channelize the transmitter, the IR lens must face towards the receiver to load the selected channel.

4) Battery cover

Insert one standard AA(1.5V) battery here, being sure the plus and minus polarity marking of battery are facing correctly. Although rechargeable NI-CAD battery can be used too, but the unit can't obtain adequate power to keep working for more than 4 hours.

Warning: don't insert the battery backwards, Or it maybe cause severe damage to your transmitter and will void your warranty.

Option # 3

Body-Pack transmitter

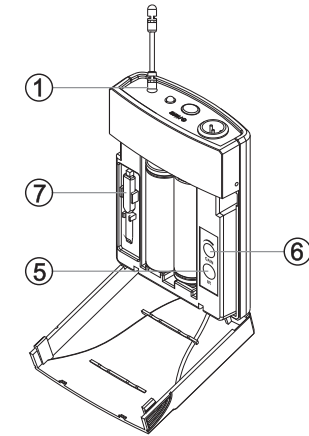
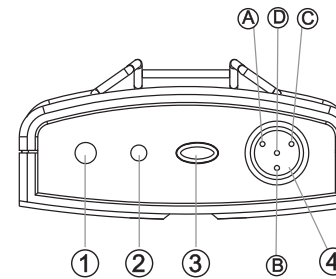

1) Antenna

This permanently attached transmitter antenna should be fully extended during normal operation-

2) Status Indicator

This LED displays the operation mode:

GREEN	Normal Operation
RED	"MUTE"
Flashing RED	Low power

3) Power/Mute Switch

Press and hold to turn the unit on or off. Press and release to mute or unmute the transmitter.

4) Mini 4P connector

- A. Pin 1: Ground (GND)
- B. Pin 2: "Phantom Power" for condenser microphones
- C. Pin 3: Designed for musical instruments (When used with cable)
- D. Pin 4: Designed for use with dynamic or condenser microphones

5) Infrared (IR)

This window is used to capture the infrared signal sent from the receiver. During IR adjustment to pair the transmitter with the receiver, the IR lens must face the receiver to load the selected channel.