

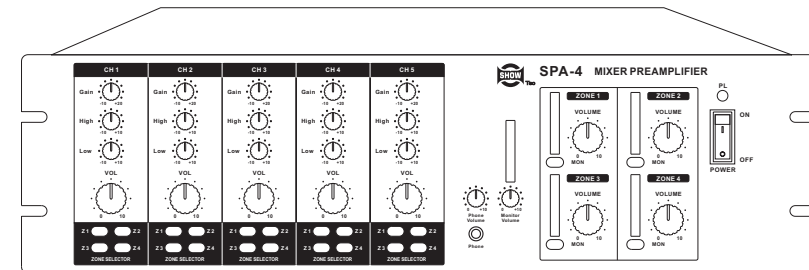

THE UNIVERSE OF INSTALLATION

MIXER PREAMPLIFIER

User's Manual



SHOW® is a registered trademark of
SEIKAKU TECHNICAL GROUP LIMITED

SEIKAKU TECHNICAL GROUP LIMITED

NO.1 LANE 17, SEC.2, HAN SHI WEST ROAD, TAICHUNG 40151, TAIWAN

tel: 886-4-22313737 - fax: 886-4-22346757

SPA-4

INDEX

01 SAFETY RELATED SYMBOLS	1
02 WARNING	1
03 IMPORTANT SAFETY INSTRUCTION	2
04 CONTROL ELEMENTS	3
05 INSTALLATION	7
06 CONNECTION DESCRIPTION	8
07 TROUBLE SHOOTING	9

TROUBLE SHOOTING

Symptom	Likely Cause	What to do
No sound	Amplifier not connected	Verify that speaker is connected and that the circuit is on
	Power not switched on	Switch on power and verify that power Led is on
No sound, amplifier is connected	Amplifier power cable is faulty or improperly connected.	*Re-seat the power cable at both ends; *Substitute a known-good power cable
	Blown fuse	*Check fuse & replace with same type "spare fuse in holder"
No sound Speaker comes on	Signal source (mixer, Amp instrument) is not sending	*Check if the signal LED indicators are lit on *Verify that the tape or CD is playing; *Use headphones to verify that the instrument is actually sending an audio signal
	Faulty cables & connections	*Disconnect and re-seat signal cables; *Replace suspected cable with a known-good cable
No sound with microphone connected to MIC / LINE input	Microphone requires phantom power	The EON does not supply phantom power. Switch to a dynamic microphone, use a battery powered microphone (if possible), use an external phantom power supply for condenser type microphones.
Signal sounds distorted and very loud, LIMIT light is lit most of the time	Excessive input signal, trying to exceed the capabilities of the speakers	*Reduce the output level of the source; *Turn down the level controls on the speaker; *Use additional EON speakers
Lots of hiss in sound, mixer controls are at very low settings.	Improper gain adjustment or settings	*Make sure that the MIC / LINE switch is in the LINE (disengaged) position; *Reduce the level settings at speaker, Review the Owner's Manual for your mixer and adjust controls as needed; *Input sensitivity(gain); *Channel faders; *Master faders;
Hum or Buzz	Improper A/Cgrounding, ground loops	*"lift" audio ground by using XLR/F to XLR/M adapter on one end *Re-route audio cables away from AC power and lighting cables.
	Excessively long unbalanced cable run	*Use the balanced outputs(if available)of your mixer or source equipment to drive your EON speakers. *Use"D.I"(direct injection) box to convert unbalanced equipment output to a balanced output.
	Improper system gain settings	Reduce the INPUT level controls and increase the output level of your source devices.
Speakers feed back and howl when the microphone volume is turned up	Microphone are pointed into the speakers	Move the speakers so they do not point at the microphone's pickup pattern.
	Incorrect Equalizer settings	Locate the feedback frequency and reduce it using the mixer EQ or an external equalizer.
	Excessive gain	Reduce the gain at the mixer and move the microphone closer to the sound source.

IMPORTANT!

Please read this manual carefully before operating this unit for the first time.

All rights reserved to SEIKAKU. All features and content might be changed without prior notice. Any photocopy, translation, or reproduction of part of this catalogue without written permission is forbidden. Copyright © 2009 SEIKAKU GROUP

CONNECTION DESCRIPTION

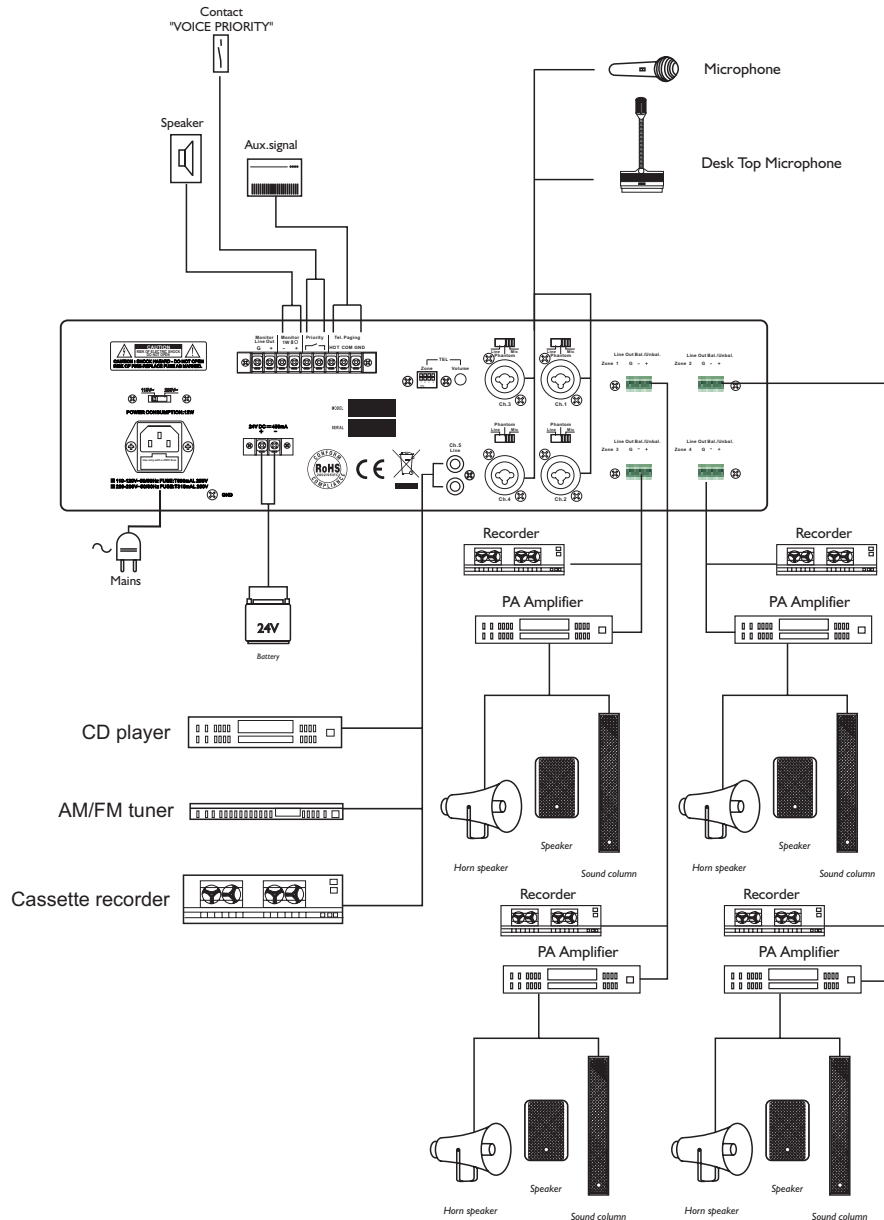

SAFETY RELATED SYMBOLS



The symbol is used to indicate that some hazardous live terminals are involved within this apparatus, even under the normal operating conditions.



The symbol is used in the service documentation to indicate that specific component shall be only replaced by the component specified in that Documentation for safety reasons.



Protective grounding terminal.



Alternating current /voltage.



Hazardous live terminal .



ON: Denotes the apparatus turns on.



OFF: Denotes the apparatus turns off, because of using the single pole switch, be sure to unplug the AC power to prevent any electric shock before you proceed your service.

WARNING: Describes precautions that should be observed to prevent the danger of injury or death to the user.



Disposing of this product should not be placed in municipal waste and should be separate collection.

CAUTION: Describes precautions that should be observed to prevent danger of the apparatus.

WARNING

• Power Supply

Ensure the source voltage matches the voltage of the power supply before turning ON the apparatus.

Unplug this apparatus during lightning storms or when unused for long periods of time.

• External Connection

The external wiring connected to the output hazardous live terminals requires installation by an instructed person, or the use of ready-made leads or cords.

• Do not Remove any Cover

There are maybe some areas with high voltages inside, to reduce the risk of electric shock, do not remove any cover if the power supply is connected.

The cover should be removed by the qualified personnel only.

No user serviceable parts inside.

• Fuse

To prevent a fire, make sure to use fuses with specified standard (current, voltage, type). Do not use a different fuse or short circuit the fuse holder.

Before replacing the fuse, turn OFF the apparatus and disconnected the power source.

• Protective Grounding

Make sure to connect the protective grounding to prevent any electric shock before turning ON the apparatus.

Never cut off the internal or external protective grounding wire or disconnect the wiring of protective grounding terminal.

• Operating Conditions

This apparatus shall not be exposed to dripping or splashing and that no objects filled with liquids, such as vases, shall be placed on this apparatus.

To reduce the risk of fire or electric shock, do not expose this apparatus to rain or moisture.

Do not use this apparatus near water. Install in accordance with the manufacture-r's instructions. Do not install near any heat sources such as radiators, heat registers, stoves, or other apparatus (including amplifiers) that produce heat. Do not block any ventilation openings.

No naked flame sources, such as lighted candles, should be placed on the apparatus.

IMPORTANT SAFETY INSTRUCTIONS

- Read these instructions.
- Follow all instructions.
- Keep these instructions.
- Heed all warnings.
- Only use attachments/accessories specified by the manufacturer.

• Power Cord and Plug

Do not defeat the safety purpose of the polarized or grounding type plug.

A polarized plug has two blades with one wider than the other. A grounding type plug has two blades and a third grounding prong. The wide blade or the third prong are provided for your safety. If the provided plug does not fit into your outlet, consult an electrician for replacement of the obsolete outlet.

Protect the power cord from being walked on or pinched particularly at plugs, convenience receptacles, and the point where they exit from the apparatus.

• Cleaning

When the apparatus needs a cleaning, you can blow off dust from the apparatus with

a blower or clean with rag etc.

Don't use solvents such as benzol, alcohol, or other fluids with very strong volatility and flammability for cleaning the apparatus body. Clean only with dry cloth.

• Servicing

Refer all servicing to qualified personnel. To reduce the risk of electric shock, do not perform any servicing other than that contained in the operating instructions unless you are qualified to do so .

Servicing is required when the apparatus has been damaged in any way , such as power supply cord or plug is damaged , liquid has been spilled or objects have fallen into the apparatus, the apparatus has been exposed to rain or moisture , does not operate normally, or has been dropped.

The mains plug is used as the disconnect device, the disconnect device shall remain readily operable.

INSTALLATION

INSTALLATION NOTES

At all times , the amplifier has to be operated under appropriate conditions. This includes that the operation location provided sufficient ventilation and the device is not exposed to direct sunlight or the direct radiation or reflection from any heat source. Installing the loudspeaker systems choose a location that gets not affected by extreme and /or constant vibration or other mechanical oscillation . Also make sure that the speakers are installed at locations that are free from dust and /or moisture.

CAUTION

We strongly recommend that you leave the connection of the appliance to the qualified and experienced service technician who is specialized in connecting electrical and electronic equipment. Do not take the risk of Electro-shock hazard. To reduce the risk of Electro-shock, all connections have to be accomplished before it is permissible to connect the amplifier t the main supply, before connecting the appliance to the mains supply, once again make certain that all connections are carried out correctly and that no short-circuit exist. The overall sound reinforcement installation has to be in accordance to the laws, regulations, standards, and guidelines that are relevant and applicable in that country where the equipment is going to be operated.

AC POWER SUPPLY

CAUTION

Before using the amplifier for the first time, make sure that the appliance's voltage is in accordance to your mains supply. Connect the amplifier only to grounded mains outlets. Connecting the amplifier to the mains supply (115/230Vac) has to be accomplished by inserting the supplied mains cord into the corresponding docket .

23. The mono MIC/LINE channels

These are the channels from Channel 1 to Channel 4. You can connect balanced, low impedance microphones to the XLR socket. On the 1/4" phone jack you can connect either a microphone or a line level instrument. You shall never connect an unbalanced microphone to the XLR socket if you do not want to damage both the Microphone and the Mixer.

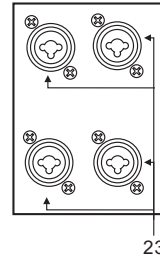

24. CH1, CH2, CH3 and CH4 inputs sensitivity and XLR phantom switch

By turning the switch onto the "LINE" position the CH1, CH2, CH3 & CH4 input can be connected to an audio source with high level signal output. By turning these switches onto the MIC position, CH1, CH2, CH3 & CH4 input can be connected to a dynamic microphone with low impedance. By turning the switch onto the "Phantom" position connects phantom supply to XLR of pin 2 and pin 3 of CH1, CH2, CH3 & CH4 necessary to operate condenser microphone which require this type of external supply. It is recommended to use this switch with the general volume set on minimum.

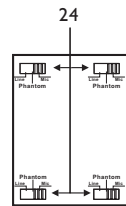

25. Line Out Bal/Unbal

These terminals can be connected to other equipments, such as amplifier, recorder, etc.

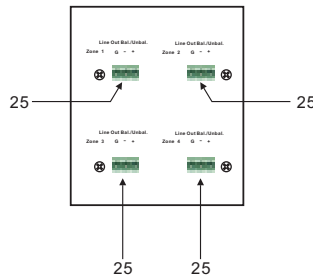

26. DC Power Supply

SPA-4 pre-amplifier can also operate using 24V DC power supply. When both the AC and DC source is connected, it shall operate using AC main whereas the DC supply shall be only consumed whenever the former failed.



CONTROL ELEMENTS

The Front panel

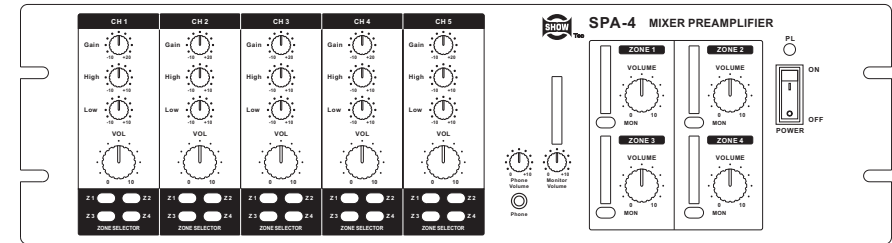

1. Gain knob

this knob controls input gain. Turn the knob clockwise, then the input increases. Turn the knob counter-clockwise, then the input decreases.

2. High knob

This is the treble control. You can use it to get rid of high frequency noises or to boost the sound of cymbals for the high harmonics of the human voice. The gain range goes from -10dB to +10dB with the central frequency 10kHz.

3. Low knob

This is the Bass control. Boost male voice or kickdrum and bass guitar. Your system will sound much bigger than what it is. The gain range goes from -10dB to +10dB and the center frequency is 100 Hz.

4. VOL knob

This knob controls volume. Turn the knob clockwise, and the volume increases. Turn the knob counter clockwise, and the volume decreases.

5. Zone selector

Z1, Z2, Z3, Z4 can be considered as signal assignment switches. Press the button Z1 down and signal will be assigned to ZONE 1. Release the button and it stops assign signal to ZONE 1. Z2, Z3, Z4 can be operated in the same way.

6. Phone Volume

This knob controls the volume of Phone (refer to 7). Turn the knob clockwise, and it increases the volume, and vice versa.

7. Phone

The signals of amplifier can be sent to a pair of headphones through this socket.

8. Monitor Volume

This knob controls the output signal level to monitor output.

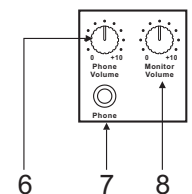
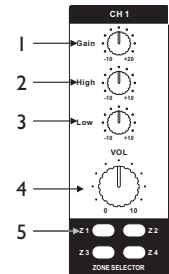

9. Zone I VOLUME

VOLUME controls the output signal level of ZONE I.

10. LED VU-meter

This stereo 6 segment LED-meter indicates the level of the overall output signal.

11. MONITOR selector

Push MONITOR button down, then it connects the signal from amplifier I to monitor volume. Release the button, then it cuts off the signal connection to monitor volume. The other three buttons are operated in the same way.

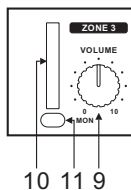

12. PL

This LED is the power indicator. When the amplifier is powered on, this LED lights up. When the amplifier is powered off, this LED lights off.

13. Power switch

When the switch is set in the position ON, the unit is powered on. When the switch is set in the position OFF, the unit is powered off.

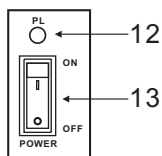

The Rear Panel

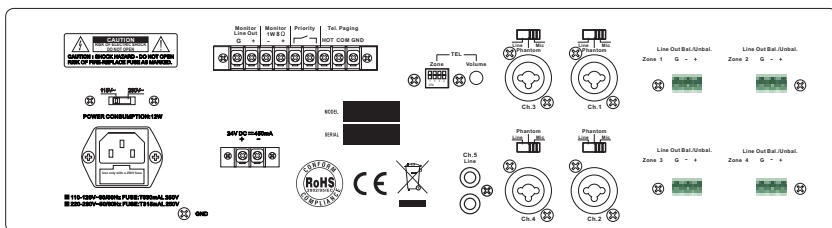

14. AC Input

Power inlet This inlet connects the unit with the main power.

15. AC fuse

The fuse protects the alternating current circuit of the unit, and the fuse can only be replaced in the event of fuse damage.

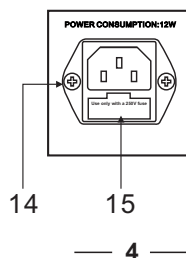

16. AC Voltage Selector

When the AC Voltage Selector is set to the left 115V, it selects the power at 100V to 127V. When the AC Voltage Selector is set to the right 230V, it selects the power at 220V to 240V.

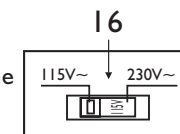

17. Monitor Line Out

Monitor Line Out can be connected with other equipments, such as amplifier, recorder, etc.

18. Monitor 1W8Ω

The terminal is meant for the connection of a small external loudspeaker that gets driven by an internal auxiliary power amplifier, providing a nominal output 1Watt. Only the mixed audio signal coming from "AUX IN" are included in the outputted signal. In addition, the output signal is controlled only by the volume control of the "CH4", "CH5", music signal level control.

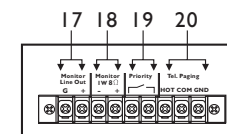

19. "Priority" Terminal.

When these terminals are short-circuited (i.e. By means of using an electrical switch), the audio signals coming from "CH4", "CH5", are attenuated while the signals coming from "CH1", "CH2", "CH3" are gaining priority.

20. Input "AUX Paging"

The terminals input lets you connect to an auxiliary signal. The input features "Voice Priority" function, which overrides all other input signals once, an auxiliary message is sent. If you want to have this function disabled forever, please contact a distributor.

21. a. Zone

There are four dip switches here. Push the dip switch up, it switches off and vice versa.

b. Volume

It controls the volume of sound source that is connected to the "Tel Paging". Turning the knob clockwise increases the volume of the corresponding source. It is recommend to leave the control of momentarily not used input at their minimal setting "0".

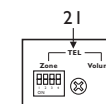

22. "LINE IN" inputs

an audio source with a high level output signal, such as an AM/FM tuner, a cassette deck, a CD player, etc. Use input sensitivity switch suitable for difference appliances. They are able to take RCA-type coaxial connectors, and unbalanced signals.

